

## MICRO POWER PACKS 700 BAR

### FEATURES

These very small single stage power packs have been specifically designed for small tools.

Their design keeps in consideration the user friendliness. Lightness, compactness and easiness to use are the best characteristics of this unit.

All models are complete with:

- Single-phase electric motor 230V - 50Hz - 0,25 kW
- 3-way 2 position solenoid.
- Relief Valve.
- Plastic tank
- Plastic casing with integrated handle
- Oil level indicator
- Electric cable 2,5 m. length with Schuko plug
- 3 m. remote control

Power packs with different voltage motors can be supplied upon request.

### APPLICATIONS

Micro pumps are ideals to control small tools like mini-presses, shears and nut-cutters.

They are compact and lightweight only 9 kilos therefore perfect in all applications where the pump must be easy to carry.



### OPTION

MC5# series series power units with 500 bar setting.

### DELIVERY DIAGRAM

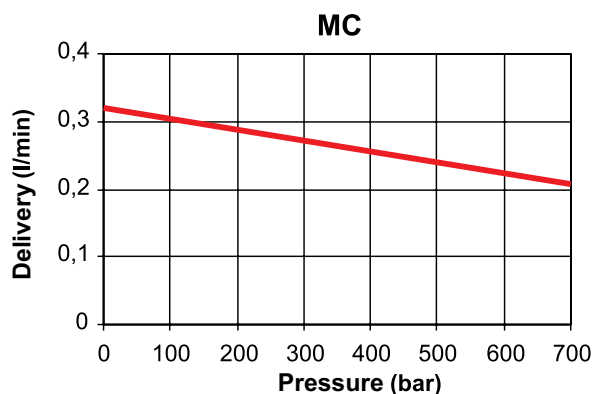

### ACCESSORIES

ZMT Carry belt.



p. 107



US series nut cutters when used with Micro power packs form a practical and handy set.

## MICRO POWER PACKS 700 BAR

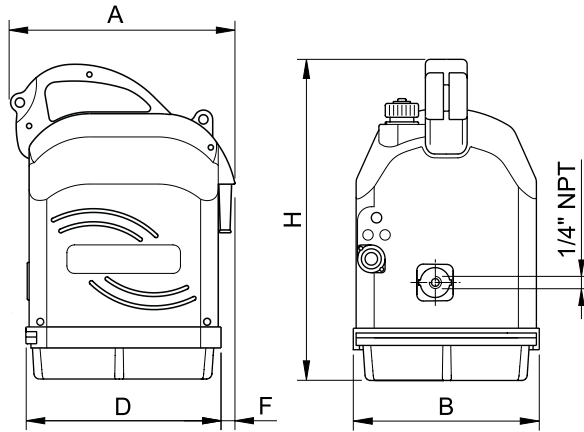

- Reservoir Capacity **1,0 l**
- Delivery at 700 bar **0,21 l/min**
- Power Rating **0,25 kW**
- Max pressure. **700 bar**

### SELECTION CHART

Maximum Pressure	Delivery at Minimum Pressure	Delivery at Maximum Pressure	Reservoir Capacity	Usable Oil Volume	MODEL	Dimensions mm					Weight
						bar	l/min	l/min	litres	litres	
700	0,32	0,21	1,0	0,8	MC71 MC72 MC73	245	197	212	15	345	9

### FUNCTION CHART

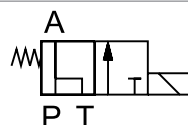
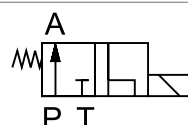
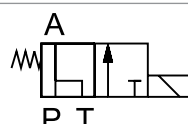
MODEL	For use with	Remote Control Function	Symbol
MC71	Single acting	Advance - Return (1 push button)	
MC72		Advance - Hold - Return (2 push buttons)	
MC73		Advance - Return (1 push button) Integrated control located at the end of the hose assembly	

### MODEL CODING

MC	7	#
Series	Pressure setting	Control type