

HEXAGONAL SOCKETS

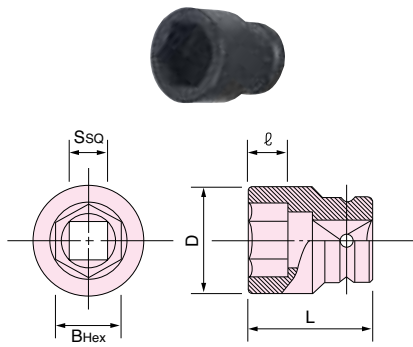

AC No.	Bolt Size		Size					Models
	M	W	S (SQ) mm(in)	B (Hex) mm	L mm	l mm	D mm	
1101	4	-	9.53 (3/8)	7	20	4	13	FPT-110~770
1102	5	-		8	25	5	13	FLT-4-1~5-1
1103	6	1/4		10	25	7	16	FPW-110~770
1104	7	-		11	25	7	18	FL-4-1~5-1
1133	8	-		12	25	8	19	FW-5
1105	8	-		13	27	8	20	FW-6, 44~66
1106	-	5/16	14	27	8	22		
2101	6	1/4	12.7 (1/2)	10	35	7	18	
2118	8	-		12	35	8	21	FLT6-1~9-1
2102	8	-		13	35	8	21	FL6-1~9-1
2103	-	5/16		14	38	9	23	FW-6PH-11
2104	10	3/8		17	38	10	27	FW-8
2105	12	7/16		19	40	12	30	FW-88, 10, 14
2106	-	1/2		21	40	14	33	except for FW-14PH-3
2107	14	-		22	43	14	34	
4102	-	1/2		21	50	13	33	
4103	14	-		22	50	14	35	FPT-1660
4104	16	-	24	53	14	38	FPW-1660, 2220	
4105	-	5/8	26	53	15	40	FW-19	
4106	18	-	27	53	15	42	FW-2C	
4107	20	-	30	55	16	46	FW-250P-2	
4108	22	3/4	32	55	18	49		
5104	-	7/8	25.4 (1)	35	62	19	55	
5105	24	-		36	62	19	56	
5106	27	1		41	68	26	63	
5107	30	1-1/8		46	72	26	69	FW-1C
5108	33	1-1/4		50	75	28	73	FW-250P-1
5109	-	1-3/8		54	80	28	78	FW-320
5110	36	-		55	80	28	80	FW-420
5111	-	1-1/2		58	80	31	83	
5112	39	-		60	80	32	86	
6105	36	-		55	82	27	83	
6106	-	1-1/2	58	85	28	87	FW-420-2, 2C	
6107	39	-	60	88	30	89		
7107	-	1-5/8	38.1 (1 1/2)	63	100	30	96	
7108	42	-		65	100	32	98	
7109	-	1-3/4		67	100	33	101	FW-50-7
7110	45	-		70	100	34	104	
7112	48	-		75	105	36	109	
7113	-	2		77	105	38	112	
8110	-	2	63.5 (2 1/2)	77	128	38	122	
8112	56	2-1/4		85	132	43	130	
8114	64	2-1/2		95	140	49	145	
8115	68	-		100	152	52	150	FW-75-7
8116	72	-		105	154	54	168	FW-100-1
8117	-	3		110	160	60	168	
8120	90	3-1/2		130	170	70	192	
8122	100	4		145	180	79	213	

*Other socket sizes are available on request.

EXTENSION BARS

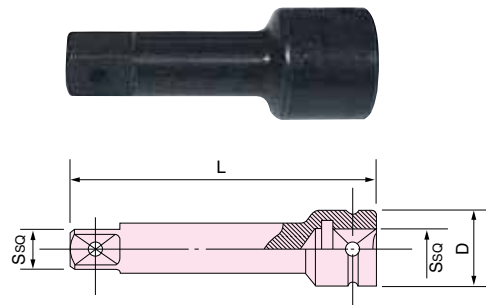

AC No.	Size			Models
	S (SQ) mm(in)	L mm	D mm	
1201	9.53 (3/8)	50	19	FPT-110~770
1202		75		FLT-4-1~5-1
1203		100		FL-4-1~5-1
1204		150		FPW-110~770
2201	12.7 (1/2)	50	25	FW-5, 6, 44~66
2202		75		FLT6-1~9-1
2203		100		FL6-1~9-1
2204		150		FW-6PH-11, 8, 88
4201	19.0 (3/4)	75	37	FW-10, 14 except for FW-14PH-3
4202		100		FPT-1660, FPW-1660, 2220
4203		150		FW-19
4204		200		FW-2C
5201	25.4 (1)	100	49	FW-250P-2
5202		160		FW-1C
5203		200		FW-250P-1
5204		300		FW-320
6201	31.8 (1 1/4)	150	62	FW-420
6202		200		
6203		250		FW-2C
6204		300		
7204	38.1 (1 1/2)	200	69	FW-50-7
7201		300		
8201	63.5 (2 1/2)	300	130	FW-75-7
8202		457		FW-100-1

UNIVERSAL JOINTS

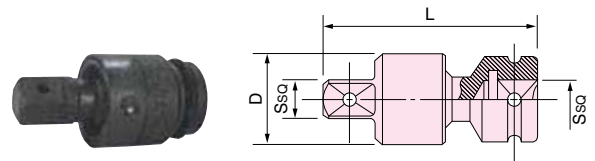

AC No.	Size			Models
	S (SQ) mm(in)	L mm	D mm	
1501	9.53(3/8)	48	24	FLT-4-1~9-1
				FPT-110
2502	12.7(1/2)	68	32	FL-4-1~9-1
				FPW-110
4502	19.0(3/4)	112	52	FW-5, 6, 44~66
5502	25.4(1)	128	61	FW-11-1-20S-1, FL11-1-13-1
6502	31.8(1 1/4)	151	74	FW-6PH-11, 8, 88
7503				38.1(1 1/2)
	19.0(3/4)	112	52	FPT-1660, FPW-1660, 2220
	25.4(1)	128	61	FW-19
	31.8(1 1/4)	151	74	FW-2C
	38.1(1 1/2)	202	102	FW-250~420
	38.1(1 1/2)	202	102	FW-50-7

Accessories

BITS SELECTION GUIDE

Fuji offers two types of screwdriver bits according to their neck length. Select suitable models or bits using the following table. Our screwdriver bits are available in three different categories of hardness to cover almost all applications: H (hard), G (standard), E (soft). The most common hardness bit are listed. Other hardness's are available on request.

GROUP	MODELS
(1)	FPT-110D-10, FLT-4D-1~4D-10~5D-1~5D-10~6D-1~6D10, 110SD-10, 330SD-10, 440SD-10, 550SD-10, 660SD-10 FPW-110D-10, 770D-30 - FL-4D-10~5D-10~6D-10, 110SD-10, 330SD-10, 440SD-10, 550SD-10, 660SD-10 FW-5SXD-70, 80, 6SXD-60, 5PXD-60, 6PMD-10, 6PLD-10, 6PXD-60, 6PHD-10, 44SAD-10, 66SAD-10, 44PAD-20, 66PAD-20
(2)	FPT-110D-1, FLT-4D-1~4D-10~5D-1~5D-10~6D-1~6D10, 110SD-1, 330SD-1, 440SD-1, 550SD-1, 660SD-1 FPW-110D-1, 770D-3 - FL-4D-1~5D-1~6D-1, 110SD-1, 330SD-1, 440SD-1, 550SD-1, 660SD-1 FW-5SXD-7, 8, 6SXD-6, 5PXD-6, 6PMD-1, 6PLD-1, 6PXD-6, 6PHD-1, 44SAD-1, 66SAD-1, 44PAD-2, 66PAD-2, FD-4, 5, 4P, 5P

SLOTTED BITS

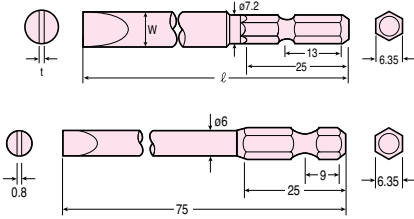

Thickness mm	Width mm	Length mm	Hardness	AC No.	Model Group
0.8	6	45	G	A166045	(1)
0.8	6	70	G	A166070	(1)
1.0	8	45	G	A168045	(1)
1.0	8	70	G	A168070	(1)
1.2	10	52	G	A161052	(1)
1.2	10	70	G	A161070	(1)
0.8	6	75	E	B356075	(2)

*Minimum order required : 100pcs. /item.

CROSS RECESSED BITS SINGLE-ENDED

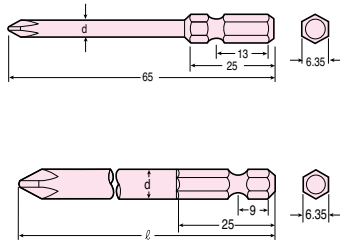

Diameter mm	Point Size	Length mm	Hardness	AC No.	Model Group
3	1	65	H	A161065	(1)
4.5	2	65	H	A162065	(1)
7	1	50	H	B351050	(2)
7	1	75	H	B351075	(2)
4.5	1	100	H	B351100	(2)
7	2	50	G	B352050	(2)
7	2	75	G	B352075	(2)
7	2	100	G	B352100	(2)
7	2	150	G	B352150	(2)
4.5	2	100	H	B252100	(2)
7	3	75	E	B353075	(2)
7	3	100	E	B353100	(2)
7	3	150	G	B353150	(2)

*Minimum order required : 100pcs. /item.

CROSS RECESSED BITS DOUBLE-ENDED

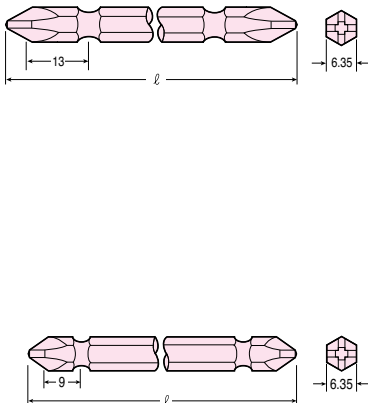

Point Size	Length mm	Hardness	AC No.	Model Group
1	45	H	A141045	(1)
1	65	H	A141065	(1)
1	110	H	A141110	(1)
2	45	G	A142045	(1)
2	65	G	A142065	(1)
2	110	G	A142110	(1)
2	150	G	A142150	(1)
2	200	G	A142200	(1)
2	300	G	A142300	(1)
3	45	E	A143045	(1)
3	65	E	A143065	(1)
3	110	E	A143110	(1)
1	75	H	B431075	(2)
2	50	H	B432050	(2)
2	75	G	B432075	(2)
2	100	G	B432100	(2)
2	150	G	B432150	(2)
2	200	G	B432200	(2)
3	75	E	B433075	(2)
3	100	E	B433100	(2)

*Minimum order required : 100pcs. /item.

CROSS RECESSED BITS DOUBLE-ENDED TORSION TYPE

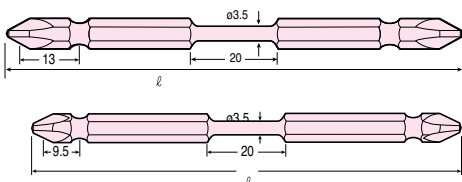

Diameter mm	Point Size	Length mm	Hardness	AC No.	Model Group
3.5	2	65	H	AT142065	(1)
3.5	2	110	H	AT142110	(1)
3.5	2	75	H	BT432075	(2)
3.5	2	100	H	BT432100	(2)

*Minimum order required : 100pcs. /item.

ALLEN BITS

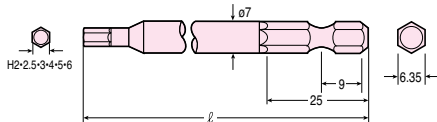
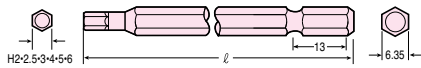

Hex Size mm	Length mm	Hardness	AC No.	Model Group
2	65	H	A16H2065	(1)
2	110	H	A16H2110	(1)
2.5	65	H	A16H25065	(1)
2.5	110	H	A16H25110	(1)
3	65	H	A16H3065	(1)
3	110	H	A16H3110	(1)
4	65	H	A16H4065	(1)
4	110	H	A16H4110	(1)
5	65	G	A16H5065	(1)
5	110	G	A16H5110	(1)
6	65	G	A16H6065	(1)
6	110	G	A16H6110	(1)
2	75	H	B35H2075	(2)
2	100	H	B35H2100	(2)
2.5	75	H	B35H25075	(2)
2.5	100	H	B35H25100	(2)
3	75	H	B35H3075	(2)
3	100	H	B35H3100	(2)
4	75	H	B35H4075	(2)
4	100	H	B35H4100	(2)
5	75	G	B35H5075	(2)
5	100	G	B35H5100	(2)
6	75	G	B35H6075	(2)
6	100	G	B35H6100	(2)

*Minimum order required : 100pcs./item.

TORX® BITS

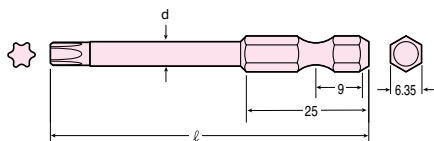
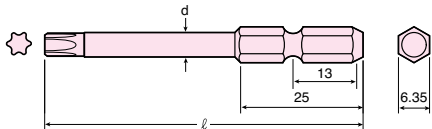

Point Size	Length mm	Body Diameter mm	AC No.	Model Group
T6	65	4.0	VT6065	(1)
T8	65	4.5	VT8065	(1)
T8	110	4.5	VT8110	(1)
T10	65	4.5	VT10065	(1)
T10	110	4.5	VT10110	(1)
T15	65	4.5	VT15065	(1)
T15	110	4.5	VT15110	(1)
T20	65	5.0	VT20065	(1)
T20	110	5.0	VT20110	(1)
T25	65	5.0	VT25065	(1)
T25	110	5.0	VT25110	(1)
T27	65	5.5	VT27065	(1)
T27	110	5.5	VT27110	(1)
T30	65	6.0	VT30065	(1)
T30	110	6.0	VT30110	(1)
T40	65	H6.35	VT40065	(1)
T40	110	H6.35	VT40110	(1)
T6	75	4.0	JT6075	(2)
T6	100	4.0	JT6100	(2)
T8	75	4.5	JT8075	(2)
T8	100	4.5	JT8100	(2)
T10	75	4.5	JT10075	(2)
T10	100	4.5	JT10100	(2)
T15	75	4.5	JT15075	(2)
T15	100	4.5	JT15100	(2)
T20	75	5.0	JT20075	(2)
T20	100	5.0	JT20100	(2)
T25	75	5.0	JT25075	(2)
T25	100	5.0	JT25100	(2)
T27	75	5.5	JT27075	(2)
T27	100	5.5	JT27100	(2)
T30	75	6.0	JT30075	(2)
T30	100	6.0	JT30100	(2)
T40	75	7.0	JT40075	(2)
T40	100	7.0	JT40100	(2)
T45	75	8.0	JT45075	(2)
T45	100	8.0	JT45100	(2)

*Minimum order required : 100pcs./item.

*TORX® is a registered trademark of Camcar Div., Textron Inc., USA.

Accessories

SOCKET HEAD BITS

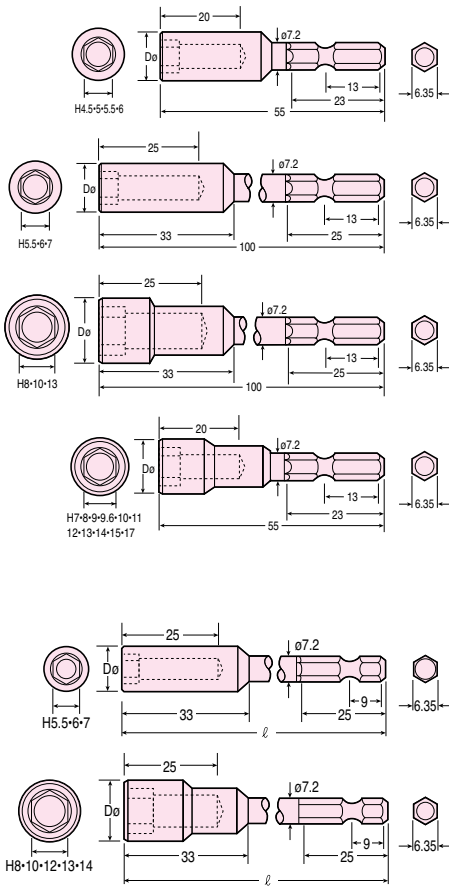

Hex Size	Length	Body Diameter	AC No.	Model Group
mm	mm	mm		
4.5	55	7.5	A2045055	(1)
5	55	8.5	A205055	(1)
5.5	55	10	A2055055	(1)
5.5	100	10	A2055100	(1)
6	55	10	A206055	(1)
6	100	10	A206100	(1)
7	55	13	A207055	(1)
7	100	13	A207100	(1)
8	55	13	A208055	(1)
8	100	13	A208100	(1)
9	55	16	A209055	(1)
10	55	16	A2010055	(1)
10	100	16	A2010100	(1)
11	55	16	A2011055	(1)
12	55	19	A2012055	(1)
12	100	19	A2012100	(1)
13	55	19	A2013055	(1)
13	100	19	A2013100	(1)
14	55	20	A2014055	(1)
15	55	22	A2015055	(1)
17	55	23	A2017055	(1)
5.5	75	10	B4555075	(2)
5.5	100	10	B4555100	(2)
6	100	10	B456100	(2)
7	75	13	B457075	(2)
7	100	13	B457100	(2)
8	75	13	B458075	(2)
8	100	13	B458100	(2)
8	150	13	B458150	(2)
10	75	16	B4510075	(2)
10	100	16	B4510100	(2)
10	150	16	B4510150	(2)
12	100	18	B4512100	(2)
13	75	19	B4513075	(2)
13	100	19	B4513100	(2)
14	100	20	B4514100	(2)

*Minimum order required : 100pcs./item.

ALLEN SOCKETS

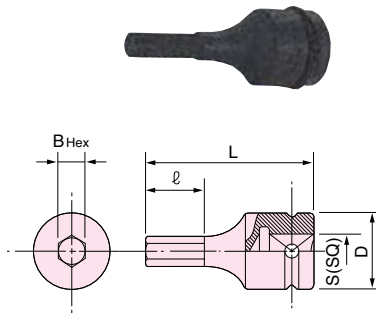

AC No.	Size					Models
	S (SQ)	B (Hex)	L	ℓ	D	
	mm(in)	mm	mm	mm	mm	
HG-3-4	9.53 (3/8)	4	50	15	19	FPT-110~770
HG-3-5		5	50	17	19	FLT-4-1~9-1
HG-3-6		6	50	18	19	FL-4-1~9-1
HG-3-8		8	60	23	20	FPW-110~770
HG-3-10		10	60	27	20	FW-5, FW-6, 44~66
HG-4-6	12.7 (1/2)	6	60	18	25	FLT-11-1~20S-1
HG-4-8		8	60	23	25	FL-11-1~13-1
HG-4-10		10	68	27	27	FW-6PH-11, 8, 88
HG-4-12		12	68	30	27	FW-10, 14 except for FW-14PH-3
HG-4-14		14	78	40	28	

CHUCKS FOR WRENCHES FOR USE OF BITS

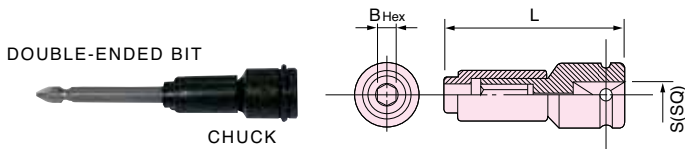

AC No.	Size			Models
	S (SQ)	B (Hex)	L	
	mm(in)	mm	mm	
DC-1	9.53(3/8)	6.35(1/4)	51	FPT-110, FLT-4-1~9-1 FPW-110, FL-4-1~9-1, FW-5, 6, 44~66
DC-2	12.7(1/4)	8.00(5/16)	56	FLT-11-1~20S-1 - FL11-1~13-1 FW-6PH-11, 8, 88, 10, 14 except for FW-14PH-3

TOOL COVER FOR FPW SERIES

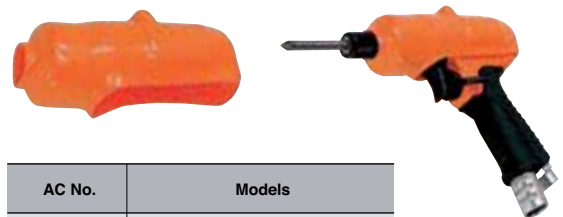

AC No.	Models
TCV-1	FL-5-1~6-1
TCV-2	FL-7-1